

# **12 ft Diameter Fan Comparison Between Epoch 2.0 and BigAss Powerfoil X3.0 Series**

**by**

**Falco eMotors**



May 22, 2020

<http://www.epochfans.com/>

**Executive Summary:** A 34-point comparison is done between Epoch 2.0 and BigAss Powerfoil X3.0 Series HVLS fans. This paper recommends Epoch 2.0 HVLS fans for reasons of high performance, efficiency, reliability, technology, lower cost of acquisition, operation and ready availability.

**Abstract:** This article presents a side by side comparison between Epoch 2.0 HVLS fans and BigAss Powerfoil X3.0 Series HVLS fans. Published Specifications and Website information are taken into consideration. Parameters such as motor power, blade diameter, fan speed, current consumption, input voltage, power factor, torque, motor weight, number of blades, installation, etc. are compared between the various companies.

**Introduction:** Direct drive platforms for HVLS fans are gaining in popularity over the past few years. Several companies have launched their direct drive platforms since 2014 including Macroair, BigAss, Greenheck, and Hunter etc... Several attempts have been made by other HVLS fan companies to manufacture direct drive fans. Most are either in the development stage or have experimented with various

May 22, 2020

<http://www.epochfans.com/>

available direct drive platforms.. Most of the manufacturers have an abysmal understanding of the characteristics of the motors and inverters required for HVLS fan performance. This paper limits its comparison between one type of Epoch 2.0 Ø12ft HVLS fan and BigAss Powerfoil X3.0 Series Ø12ft HVLS Fan.

**Epoch 2.0 Fans:** Epoch 2.0 fans are built using expanded diameter fractional slot permanent magnet synchronous motor (EDFS-PMSM) technology. The motor is controlled using power factor corrected field-oriented controls with space vector modulation. Epoch 2.0 Fans have been developed by Falco eMotors located in the state of Virginia, USA. The technology has been developed in collaboration with some major US and Canadian companies specializing in the sale of HVLS fans. The company has several fan models available from 6ft to 24ft based on Epoch 0.5, 1.0, 2.0 and 3.0 motor platforms .

**BigAss Powerfoil X3.0 Series Fans:** BigAss Powerfoil X3.0 Series has only one platform - Industrial Grade. BigAss fans facility located in Lexington, KY. Big Ass Fan, used motor and gearbox combination to drive the High volume low speed fan. The motor technology is older which uses Geared motor. BigAss Powerfoil X3.0 Series used Motor controls are not power factor corrected and did not use field-oriented controls or space vector modulation which are the latest state of the art controls.

May 22, 2020

<http://www.epochfans.com/>

*Table 1: Summary of 10' HVLS/Industrial Fan Comparison*  
**Epoch 2.0 vs BigAss Powerfoil X3.0 Series**

<i>for ø12ft (3.6m)</i>	<b>Epoch 2.0</b>	<i>BigAss Powerfoil X3.0 Series</i>
Diameter (ft./m)	6ft to 24ft	8ft to 24ft
1.. Motor Technology	<b>Latest Technology - EDFs-PMsM</b>	Old Technology - Industrial-Grade Motor with Gearbox
2. Controls	<b>Power Factor Corrected, Field Oriented Controls with Space Vector Modulation (PFC + FOC + SVPWM)</b>	<i>Onboard Variable Frequency drive</i>
3. Input Power (hp)	<b>1.5 hp Max</b>	1.5 hp
4. Sound Level (dB) at Max Speed	<b>&lt;35</b>	Very Noisy
5. Torque (Nm)	90 Nm	Very Low
6. Input Current (A)	<b>4.5A (1Φ)</b>	30A (1Φ)
7.. Power Factor Correction	<b>Yes</b>	No
8. Power Factor	<b>0.99</b>	Not Specified
9. Smartphone Interface	<b>Yes</b>	No
10. Weight (kg)	<b>67</b>	111
11. RPM	130	139
12. Coverage Area (ft 2 )	7,000	Not Specified
13. Air Flow (CFM)	3,50,000 To 4,50,000	Very Low Air Flow Volume

May 22, 2020

<http://www.epochfans.com/>

14. Input Voltage Range	200-264 VAC, 50/60 Hz, 1 $\Phi$ 200-240 VAC 50/60Hz, 3 $\Phi$ 380-480 VAC, 50/60Hz 3 $\Phi$	200–240 VAC, 50/60 Hz, 1 $\Phi$ , 200–240 VAC, 50/60 Hz, 3 $\Phi$ , 400–480 VAC, 50/60 Hz, 3 $\Phi$ ,
15. Dynamic Blade Adjustments	Yes	Not Specified
16. Analog Controls	Yes	No
17. Number of Blades	5	8
18. External VFD	Epoch VFD	Yes
19. Integrated Motor Inverter	Yes (Optional)	Yes
20. Blade Profile and Material	Airfoil Design / Anodized 6061-T6 Aluminum	Aluminum Airfoil Design
21. BACnet	Yes (Optional)	Yes
22. Fire Control Panel Integration	Yes	Yes
23. Building Management System Integration	Yes (Optional)	Yes
24. Touchscreen Console	Yes (Optional)	Yes
25. IP Rating	IP 65	IP43 , IP55 (Optional)
26. Design Safety Standards	UL507, UL1004, UL508C	UL507
27. Safety Certifications	UL 507, CE	UL 507, CE, CB
28. Life Expectancy	More than 100,000 Hours	Not disclosed
29. Warranty	Mechanical-15 yrs Electrical-7 yrs	Mechanical-15 yrs Electrical-7 yrs
30. Cost of Repair	Low	Very High

May 22, 2020

<http://www.epochfans.com/>

31. Lifetime Cost (OPEX)	Low	Very High
32. forward Reverse Operation	Yes	Yes
33. Optional Colors	Various Accent Colors(Optional)	Yes (Optional)
34. Awards	CII	Not Specified

**Discussion on the Comparisons:** In the table above, we have highlighted in green the various advantages for each of the companies. Let us discuss each of the items below.

**.1. Motor Technology:**



Epoch 2.0 Direct Drive PMSM Motor



BIGASS Powerfoil X3.0 series Motor and Gearbox Combination

May 22, 2020

<http://www.epochfans.com/>

Epoch 2.0 fans are built using expanded diameter fractional slot permanent magnet synchronous motor technology (EDFS-PMSM) which helps to improve efficiency and reduce the cost of HVLS fans dramatically. BigAss Powerfoil X3.0 Series fan uses motor and gearbox combination for high volume low-speed fan. The motor requires a gearbox filled with oil and has heavy due to the gearbox. This design has numbers of disadvantages.

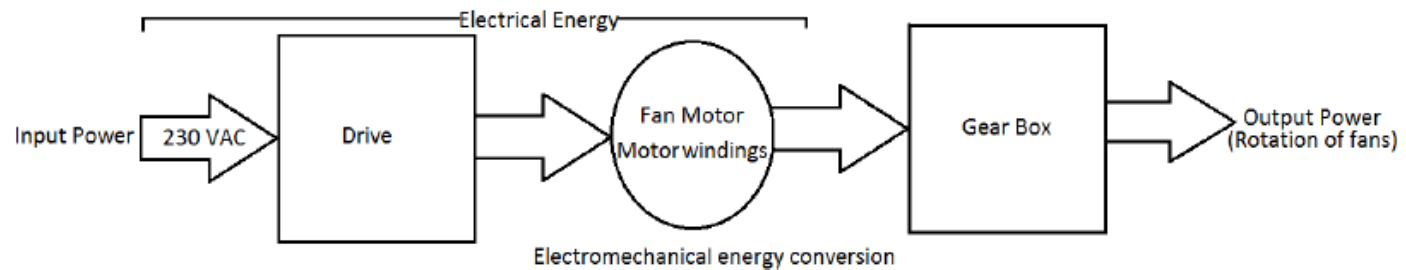

Fig: Geared Drive motor.

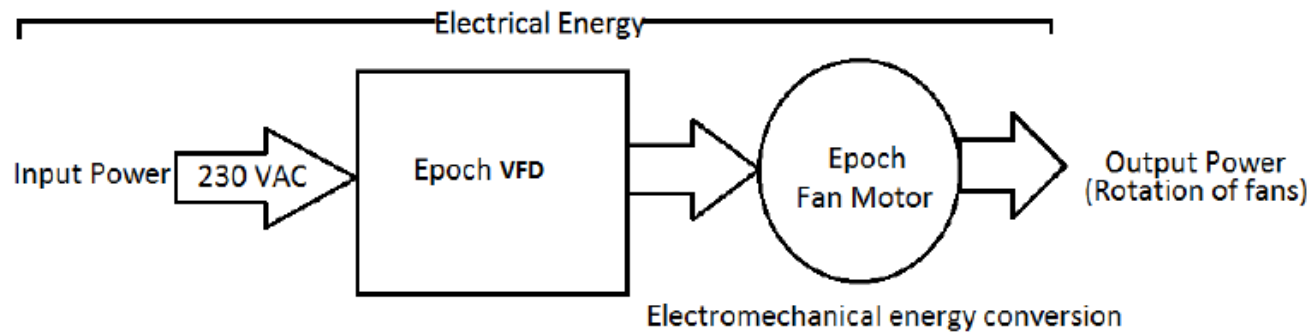

Fig: Gearless drive motor

Difference in Gear less (Epoch 2.0) vs Geared (BigAss Powerfoil X3.0 series)

May 22, 2020

<http://www.epochfans.com/>

**2. Controls:** Epoch fans use state of the art power factor corrected field oriented controls with space vector modulation which further enhances the efficiency, reduces the cost of manufacturing and operations significantly. BigAss Powerfoil X3.0 Series fans uses non-power factor corrected VFD. These controls are known to draw utility current with very high harmonics causing significant loss of efficiency and increased cost of operation and damage to other equipments

**3. Power (Watts and hp):** The Output power of a fan is a good Indicator of the amount of available airflow. Both EPOCH 2.0 fan and BigAss powerfoil X3 series fan has same power is 1.5hp

**4. Sound Level (dB) at Max Speed:** Because Epoch 2.0 fans use EDFS-PMSM technology with PFC-FOC-SVPWM controls, the sound levels at max speed are less than 35dB as compared to BigAss Powerfoil X3.0 Series fan. We have the quietest fan in the world.

**5. Torque (Nm):**BigAss Powerfoil X3.0 Series does not have a published torque number. BigAss Powerfoil X3.0 Series fans uses gearbox to achieve the high torque and low speed needed to drive an HVLS fan. These systems are electrically inefficient, bulky, heavy, hot, loud and have a short lifespan. Epoch 2.0 motors produce 90Nm of torque without using any type of gearbox.

**6. Input Current (A):** BigAss Powerfoil X3.0 Series fan draws 5 times more current i.e. 30A versus 4.5A against Epoch 2.0 fans for single phase

**7. Power Factor Correction:** There is no power factor correction built-in for BigAss Powerfoil X3.0 Series fans causing substantial power consumption during the fan operation. Epoch 2.0 fans have built-in power factor correction.

May 22, 2020

<http://www.epochfans.com/>



**8. Power Factor:** Epoch fans operate with a 0.97 to 0.99 power factor resulting in significant efficiency and cost savings. Such is not the case for BigAss Powerfoil X3.0 Series fans. Input power factor is unknown and is assumed to be 0.7 to 0.8.

**9. Smartphone Interface:** BigAss Powerfoil X3.0 Series fans do not have a Smartphone interface for running or data logging. Epoch fans can be operated with a smartphone app.



**10. Weight (kg):** BigAss Powerfoil X3.0 Series fans weight 111 vs. 67 kg for Epoch fans. The weight difference indicates that Epoch 2.0 technology is lighter than BigAss old technology. They are easier to install and maintain. On the other hand, Big Ass Powerfoil X3.0 series Fans may require additional structural support in some applications.

May 22, 2020

<http://www.epochfans.com/>



Sleek design of Epoch 2.0



Heavy and bulky design of BigAss Powerfoil X3.0

**11. RPM:** Epoch 2.0 and BigAss Powerfoil X3.0 Series fan can operate at 139 rpm at room temperature. However, Their fans speed gets reduced as motor temperature increases. Their derating is not specified in their data sheet, Epoch 2.0 fans do not de-rate and operate at 130 rpm throughout the operational temperature range.

#### *HVLS Fan and Air Flow*

*In HVLS fans, generally the volume of air supplied is given more weightage than the airflow speed. According to the paper effectiveness (cooling/destratification) of an HVLS fan is decided from the air velocity not fan speed or CFM(volume of air displaced). The air velocity of the main jet flow is of more significance than the volume of air moved, which is proved by using the ASHRAE thermal comfort tool. For air-flow of speed 29.5 to 590.6 fpm is needed to decrease the temperature of the skin of the workers working in the closed complex and reduce the temperature of the surrounding from 36*

May 22, 2020

<http://www.epochfans.com/>

*Celsius to 29 Celsius, Epoch 2.0 produces more than the required performance.*

**12. Coverage Area (ft<sup>2</sup>):** Epoch fan has the highest area coverage, i.e 7,000sq.ft. BigAss Powerfoil X3.0 Series fan not disclosed the area coverage.

**13. Air Flow (m<sup>3</sup>/s):** Epoch 2.0 fans produce the highest CFM,i.e 3,50,000 - 4,50,000 CFM. BigAss fans do not disclose the air flow figure..

**14. Input Voltage Range:** Input voltage range for the Epoch fans is substantially more comprehensive. Although Epoch fans can operate from 90 to 277V input Voltage without any damage to the controls, the performance is guaranteed between 200 and 264V, single phase input. BigAss Powerfoil X3.0 Series fans have an input voltage range options to operate on single phase , three phase.But the performance of the fan is not guaranteed while operating in such options

**15. Dynamic Blade Adjustments:** Epoch fans employ adjustable blade technology with droop down and uplift mechanism.Such blades can weather the rotational stresses efficiently as compared to stiff blades.BigAss Powerfoil X3.0 Series uses rigid blades. Also, adjustable blades produce efficient and broader air flow area as speed increases as compared to rigid blades.

May 22, 2020

<http://www.epochfans.com/>

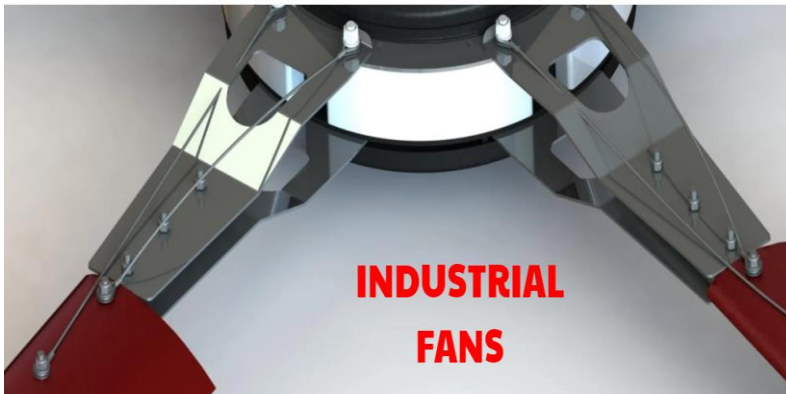

Falco Epoch 2.0 adjustable blades



BigAss Powerfoil X3.0 series Rigid blades

**16. Analog Controls:** Epoch 2.0 fans come with analog controls with a built-in speed regulator for ease of operation. Such controls are not available with BigAss Powerfoil X3.0 Series. The Epoch fan controls also have a built-in circuit breaker for added safety protection.



Image: Analog Controller

May 22, 2020

<http://www.epochfans.com/>

**17. Number of Blades:** Epoch fans come with 5-blades as compared to BigAss Powerfoil X3.0 Series fans have 8 blades. Because of the built-in de-rating in BigAss Powerfoil X3.0 Series fans, BigAss Powerfoil X3.0 Series uses 8-blades to minimize the power consumption. However, that also drastically reduces the air flow. Eight blades can produce good airflow, but they also create noise and even sound harmonics which cannot be canceled. Five bladed Epoch fans produce good airflow without producing harmful sound harmonics and turbulence resulting in high efficiency.

**18. External VFD:** Epoch 2.0 Fans are available with built in VFD. BigAss powerfoil X3.0 series need external VFD

**19. Integrated Motor Inverter:** BigAss Powerfoil X3.0 Series fans come with integrated controls. Epoch 2.0 Fans are also available with built-in controls. The issue with the integrated controls is the fact that motor heating drastically lowers the life of the electronics. Especially when the full speed of the fan is required, BigAss Powerfil X3.0 controls can begin to slow down the speed with increased motor heating. As the summer temperatures rise, BigAss Powerfil X3.0 fans run slower.

**20. Blade Profile and Material:** Blade profile and material for both the manufacturers are equivalent with airfoil blades and aluminum T6061 material.

May 22, 2020

<http://www.epochfans.com/>

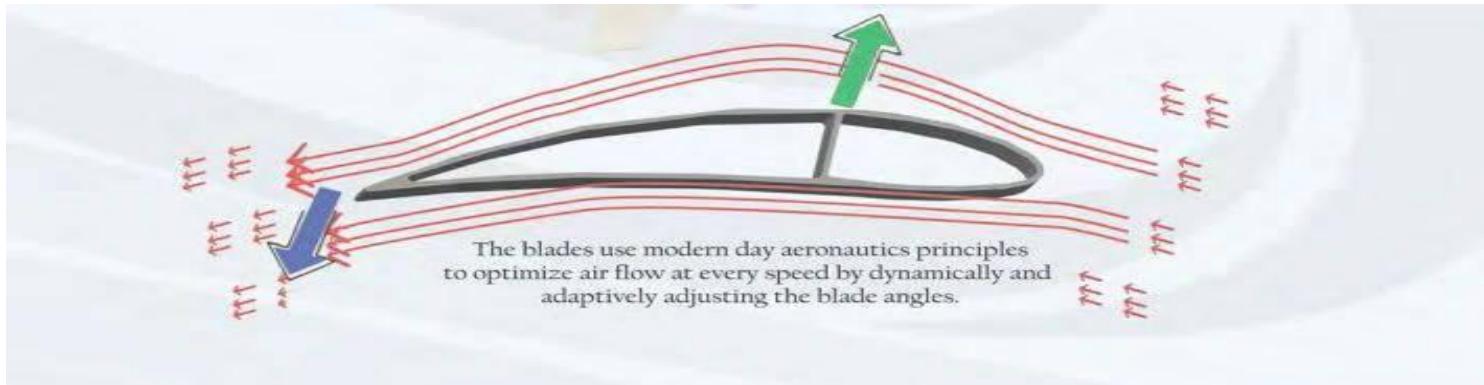

**21.BACnet:** Falco Epoch 2.0 fans have a BACnet control system. BigAss Powerfoil X3.0 series fans also provide this control system. Below figure will show its features.

## BACnet Control

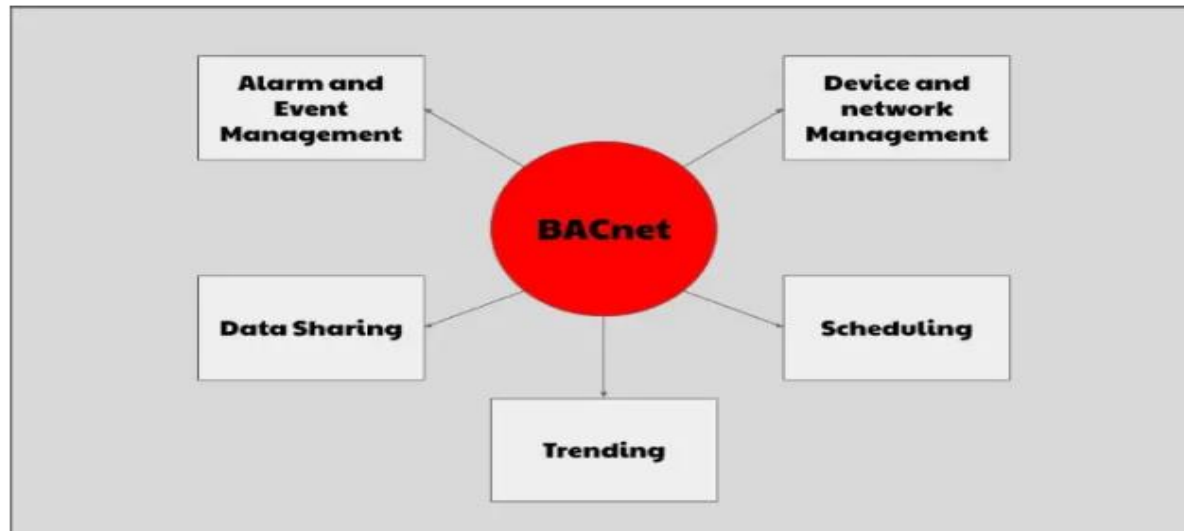

May 22, 2020

<http://www.epochfans.com/>

## Falco Epoch 2.0 BACnet control features

- 22. Building Management System Integration:** Standard building management system integration is available from both the manufacturers.
- 23. Touchscreen Console:** Standard touchscreen controls are available from both the manufacturers.
- 24. IP Rating:** Epoch fans are rated with an IP65 rating whereas BigAss Powerfoil X3.0 Series fans have IP55.
- 25. Design Safety Standards:** Epoch 2.0 fans are designed for UL507, UL1004 and UL508C safety standards. BigAss Powerfoil X3.0 Series fans are intended for the UL507 safety standard.
- 26. Safety Certifications:** Both the fans have undergone safety testing at Intertek laboratories in Dallas, Texas, USA. Epoch fans have UL507 and CE certification.
- 27. Life Expectancy:** BigAss Powerfoil X3.0 Series fans not disclose life expectancy. Epoch fans have a life expectancy of more than 100,000 hours.
- 30. Warranty:** Epoch 2.0 Fans provide the highest warranty than BigAss Powerfoil X3.0 Series fans
- 28. Cost of Repair:** BigAss Powerfoil X3.0 Series fans have a high cost of repair because of integrated controls. Integrated controls have lower life expectancy because of elevated temperatures of operation. Every repair requires the use of expensive scissor lift or scaffolding resulting in substantial downtime for the customer. Such is not the case for Epoch fans. Epoch motors have a life expectancy of more than 100,000 hours, and because they are not de-rating due to overheating, controls last much

May 22, 2020

<http://www.epochfans.com/>

longer than BigAss Powerfoil X3.0 Series 's controls.

**29. Lifetime Costs:** Lifetime costs for BigAss Powerfoil X3.0 Series fans are incredibly high. Given the high-power consumption, the high cost of acquisition, the high cost of repair and likelihood of a failure due to de-rating, lifetime costs for BigAss Powerfoil X3.0 Series fans are incredibly high.

**30. Fire Control Panel Integration:** Fire control panel system integration is available from both the manufacturers.

**31. Forward and Reverse Operation:** Forward and Reverse operation is available from both the manufacturers.

**32. Optional color:** Optional colors are available from both the manufacturers.

**33. Awards:** Epoch fan manufacturer got the most innovative company award i.e. CII award amongst top companies in India. BigAss does not have such kind of award.



CII Award to Falco eMotors for the most innovative company 2019

May 22, 2020

<http://www.epochfans.com/>



## Energy Saving report for Epoch 2.0 12-ft HVLS fans

	Epoch fan	BigAss Powerfoil X3.0	Savings (USD)
Quantity	1	1	
Fan diameter	12 ft	12 ft	
Pin (KW)	750	1100	
Pin (KVAh)	750	2200	
Total (KW)	0.75	1.1	
Total (KVAh)	0.75	2.2	
Operational hours (daily)	24	24	
Daily Power Consumption (KWh)	18	26.4	
Daily Power Consumption (KVAh)	18	52.8	
Cost/ kwh in \$	\$0.13	\$0.13	
Cost/ kVAh in \$	\$0.13	\$0.13	
Daily cost (KWh) in \$	\$2.34	\$3.43	<b>\$1.09</b>
Daily cost (KVAh) in \$	\$2.34	\$6.86	<b>\$4.52</b>
Operational days (monthly)	30	30	
Monthly cost (KWh) in \$	\$70.20	\$102.96	<b>\$32.76</b>
Monthly cost (KVAh) in \$	\$70.20	\$205.92	<b>\$135.72</b>
Operational days (yearly)	365	365	
Yearly cost (KWh) in \$	\$854.10	\$1,252.68	<b>\$398.58</b>
Yearly cost (KVAh) in \$	\$854.10	\$2,505.36	<b>\$1,651.26</b>

**Conclusion:** This paper recommends Epoch fans for various reasons. Primary reasons being high performance, high efficiency, high reliability, high technology, lower cost of acquisition, operation and maintenance and make in India availability.

May 22, 2020

<http://www.epochfans.com/>

**SHOP NOW!**

May 22, 2020

<http://www.epochfans.com/>